



Shenzhen Mason Technologies Co., Ltd (Headquarter)

Address: 18F, east building, great China international exchange square, Futian district, Shenzhen,Guangdong province,China.

Tel: +86-755-33378929

Guangdong Mason Technologies Co., Ltd (Production Base)

Address: No.1, West Industrial 1st Road, Songshan Lake, Dongguan 523808, China

Tel:+86-769-89950999 | Fax:+86-769-89950329 | E-mail:market@masonled.com

Statement : All of the product's parameters in this book are just for your reference, Mason have the right to revise or cancel the related parameters at anytime without advance notice. If you have questions, please contact our customer service hotline.

LINOS SERIES LED STREET LIGHT

LINOS SERIES LED STREET LIGHT

Professional Street Lighting
20W to 300W



Linoss Series

LINOS is a professional solution for street lighting and car parking lighting, with high energy efficiency LEDs and technical optic LENSES.



- LINOS street light, from 20W to 300W, designing five structures.
- Optional light control 3/5/7 PIN NEMA receptacle and the infrared sensor.
- SKD solution, Lenses, Glass, Upper Cover, Electrical parts etc, quickly assembly.
- Standard adjustable spigot 60mm for the whole LINOS Series.
- Tool-less access to the driver room by opening the upper cover.
- 50*50mm Lenses, optional light source of 2835/3030/5050 etc, max. 180lm/W.
- 6 in 1 or 8 in 1 lenses, with different light distribution type 2/3/4/5.
- Independent electrical compartment and light source unit, lower temperature and longer lifetime.
- The light back is smooth designed, with self-cleaning function.
- The spigot is adjustable $\pm 20^\circ$ and 2.5° per step.
- Standard version with gradienter for installation.
- The driver room well fit with both Class I and Class II LED driver.
- Optional the single light controller, Zhaga standard LED module and power disconnection switch.

SMART CONTROL

NEMA Socket 3PIN\5PIN\7PIN



Light Control and Dimming System

- We can set up and convert to lower cost version by smart control, saving energy 20%~50%, longer lifetime 2~4 times.

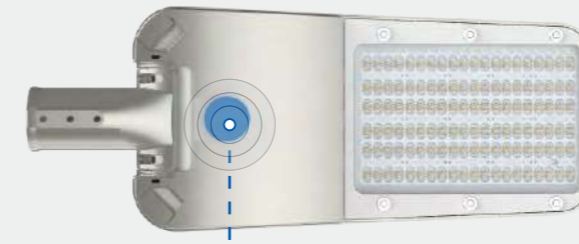

Front side designed extension knockout for motion sensor



Back side support NEMA or ZHAGA standard extension receptacle



Mobile Direct Control

**NO Gateway
NO Router**



Bluetooth



Mesh

LED Street Light

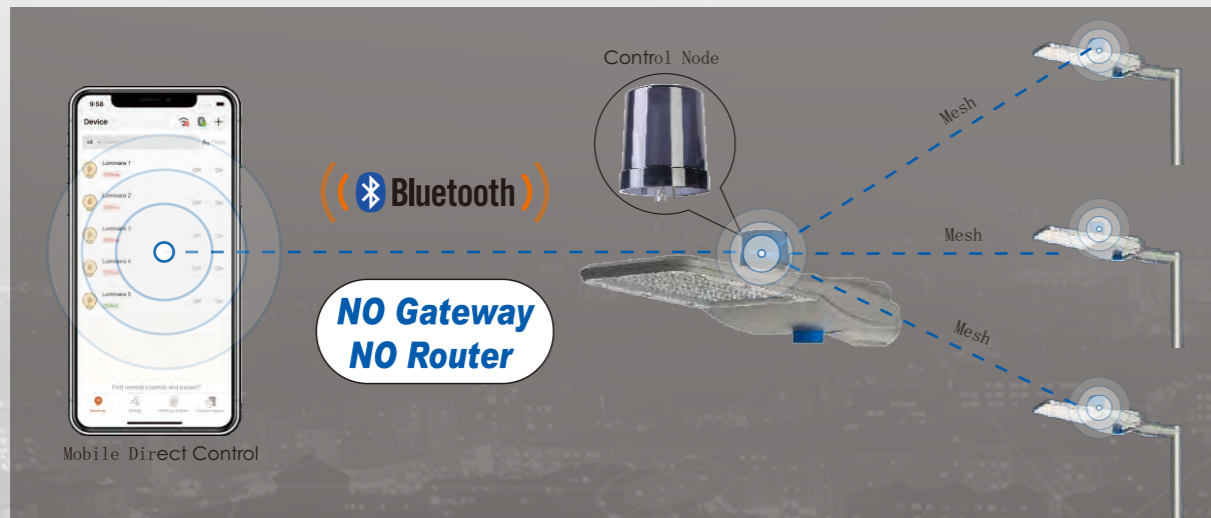

SMART CONTROL

Emergency Kit and Colour Temperature Adjustable Design

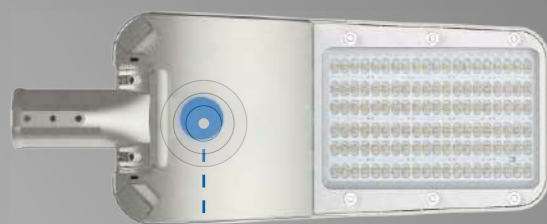

Front side designed extension knockout for motion sensor

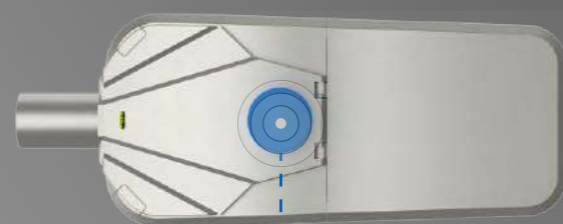

Back side support NEMA or ZHAGA standard extension receptacle



Mobile Direct Control

**NO Gateway
NO Router**



Bluetooth

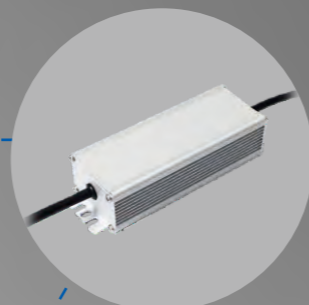

Mesh

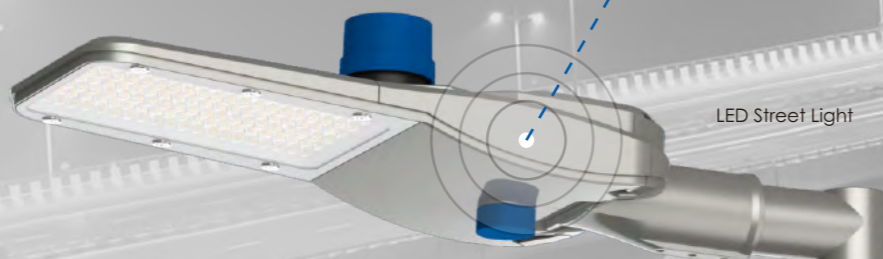

LED Street Light



Colour Temperature Adjustable Design

- LED Street Light designed with colour temperature adjustable.



Emergency Driver Kit

- Suitable for Class | LED driver, support lighting for 3h to 6h when outage.

SKD SOLUTION

The most advantageous SKD solution in the world

Quickly Disassembly and Assembly from Lenses, LED Module, Glass, Upper cover etc.

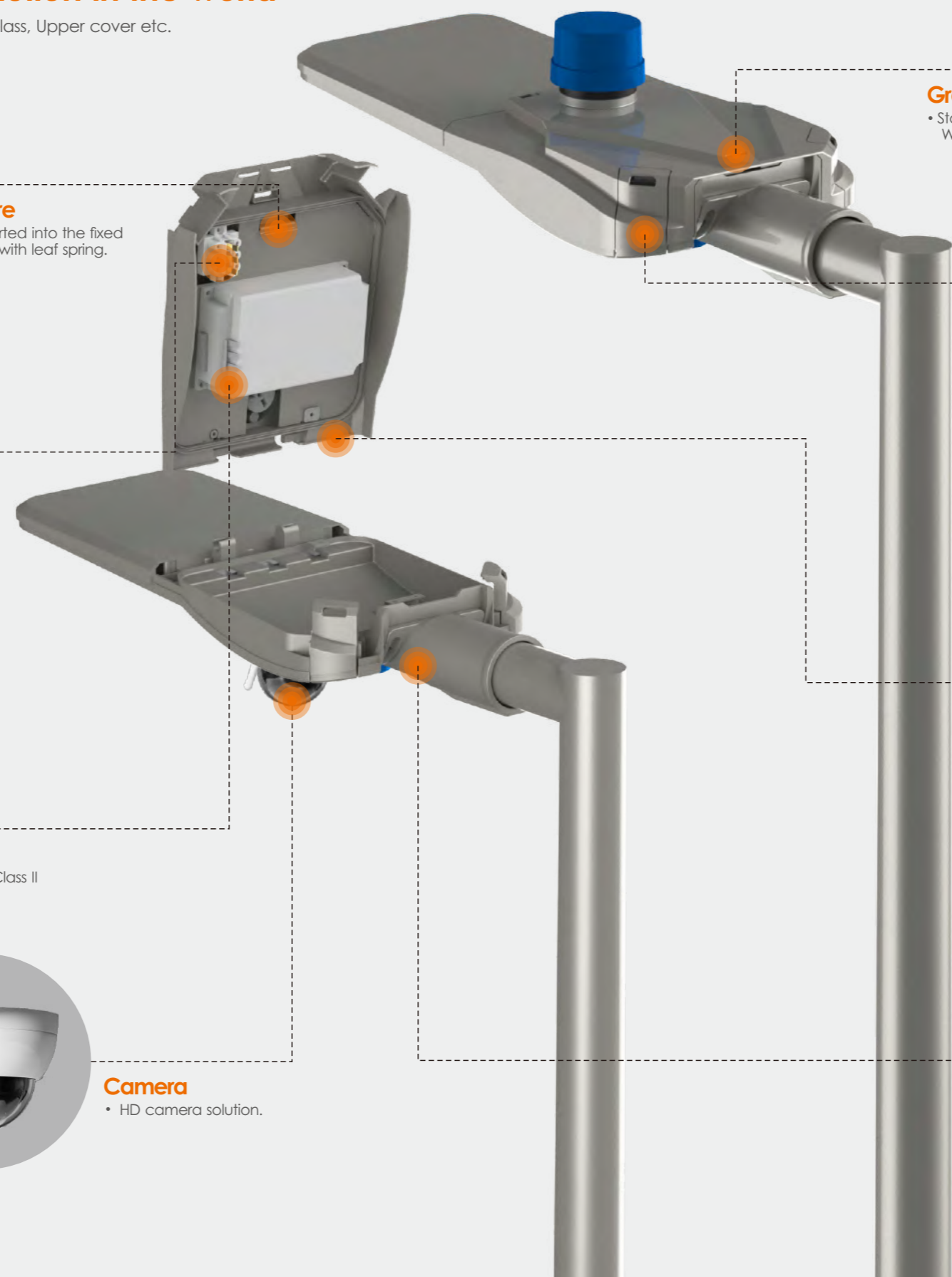

Internal Structure

- Electrical parts inserted into the fixed position, clamping with leaf spring.



Disconnection Switch

- Optional power disconnection switch.



Driver room

- Fit with both Class I and Class II LED driver.

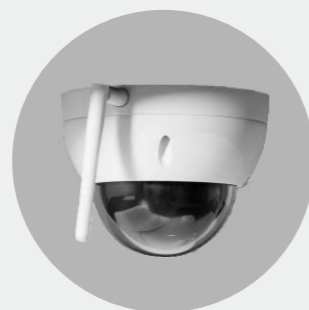

Camera

- HD camera solution.



Gradienter

- Standard Gradienter for Whole Series.



Tool-less opening the cover

- Access by opening the upper cover.
- Clips style.
- The upper cover fit with the the hole position of housing.
- Pressing the clips to close the cover.



Light source and electrical room are independently

- Achieving lower temperature and longer lifetime.



Separate Type Light Arm Design

- Adjustable spigot designed, standard 60mm.
- And provide customized size spigot solutions.

SMOOTH LUMINAIRE HOUSING DESIGN

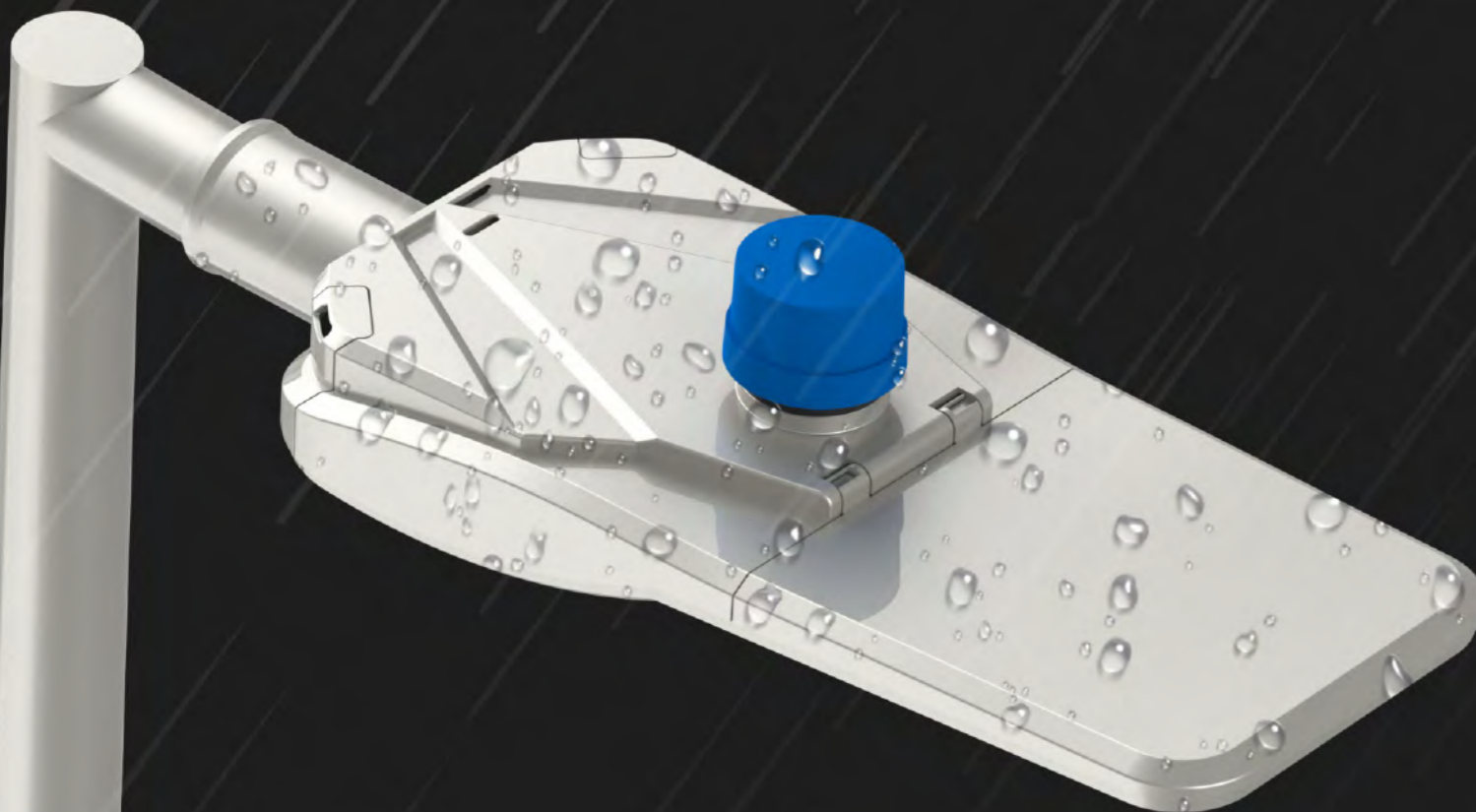

Smooth Luminaire Body, with Self-cleaning Function

Fashion design, smooth housing, preventing dust or water retention. Modern exterior design, highly favored among customers.

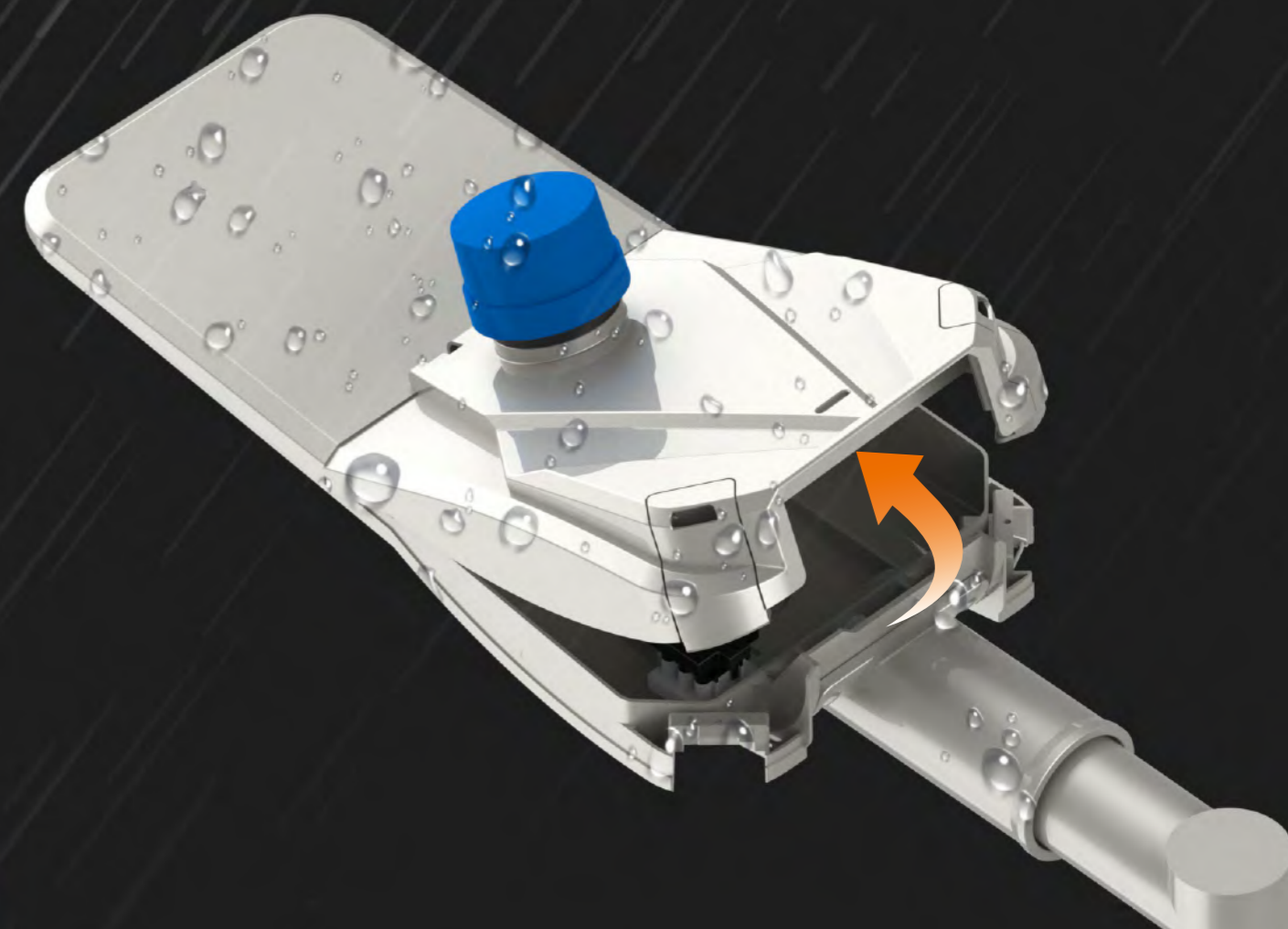

External Wrapping Structure Waterproof Design

Upper cover opening design feature, wrapping the LED driver compartment, waterproof by the structure, the water flows down when raining. LINOS has double waterproof function by adding the internal waterproof rubber ring.

TILT ANGLE ADJUSTABLE DESIGN

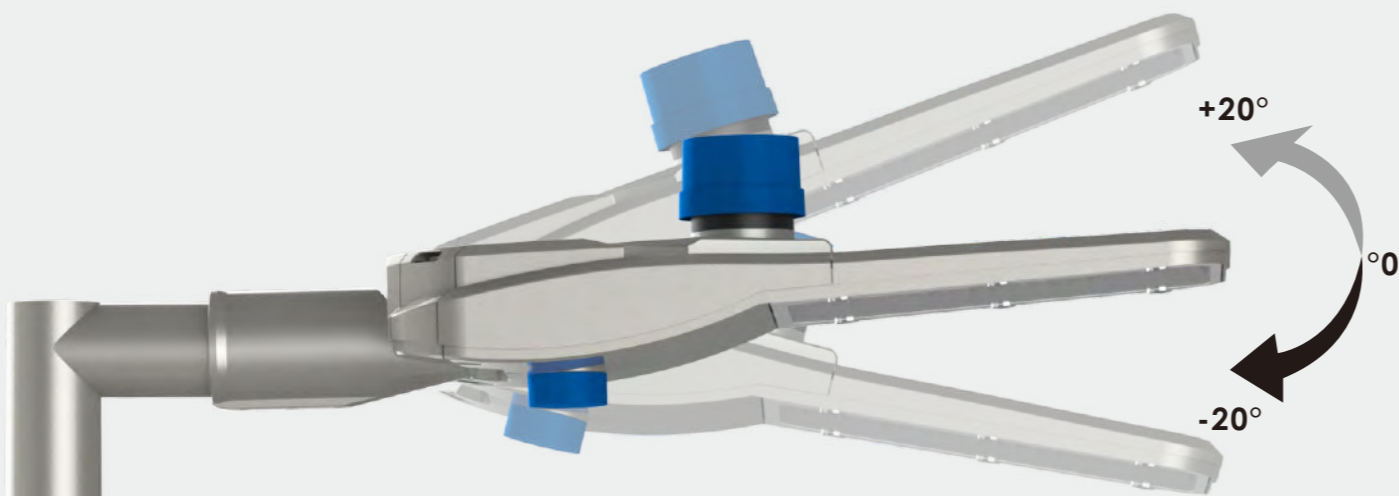

Luminaire Angle Adjustable Design

Tilt angle adjustable for installation $\pm 20^\circ$
and 2.5° per step.



LIGHT SOURCE LENS



Combined Type Lenses design

50*50mm lenses.
Available 6 in 1 or 8 in 1 lenses, with light distribution type2/3/4/5.

Light Source for Options

Optional light source 3030/2835/5050 up to 180lm/W.

Light distribution curve

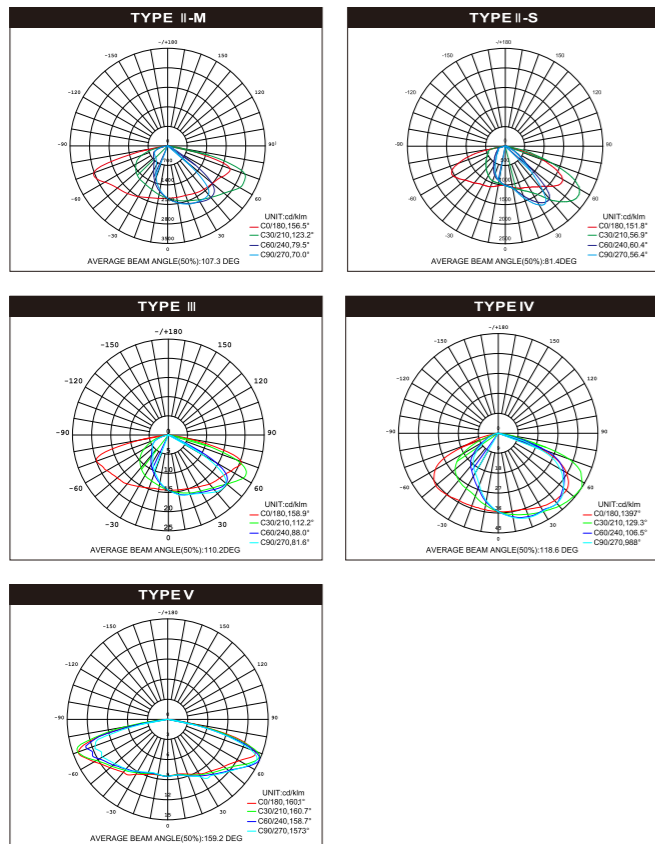

Isolux curve

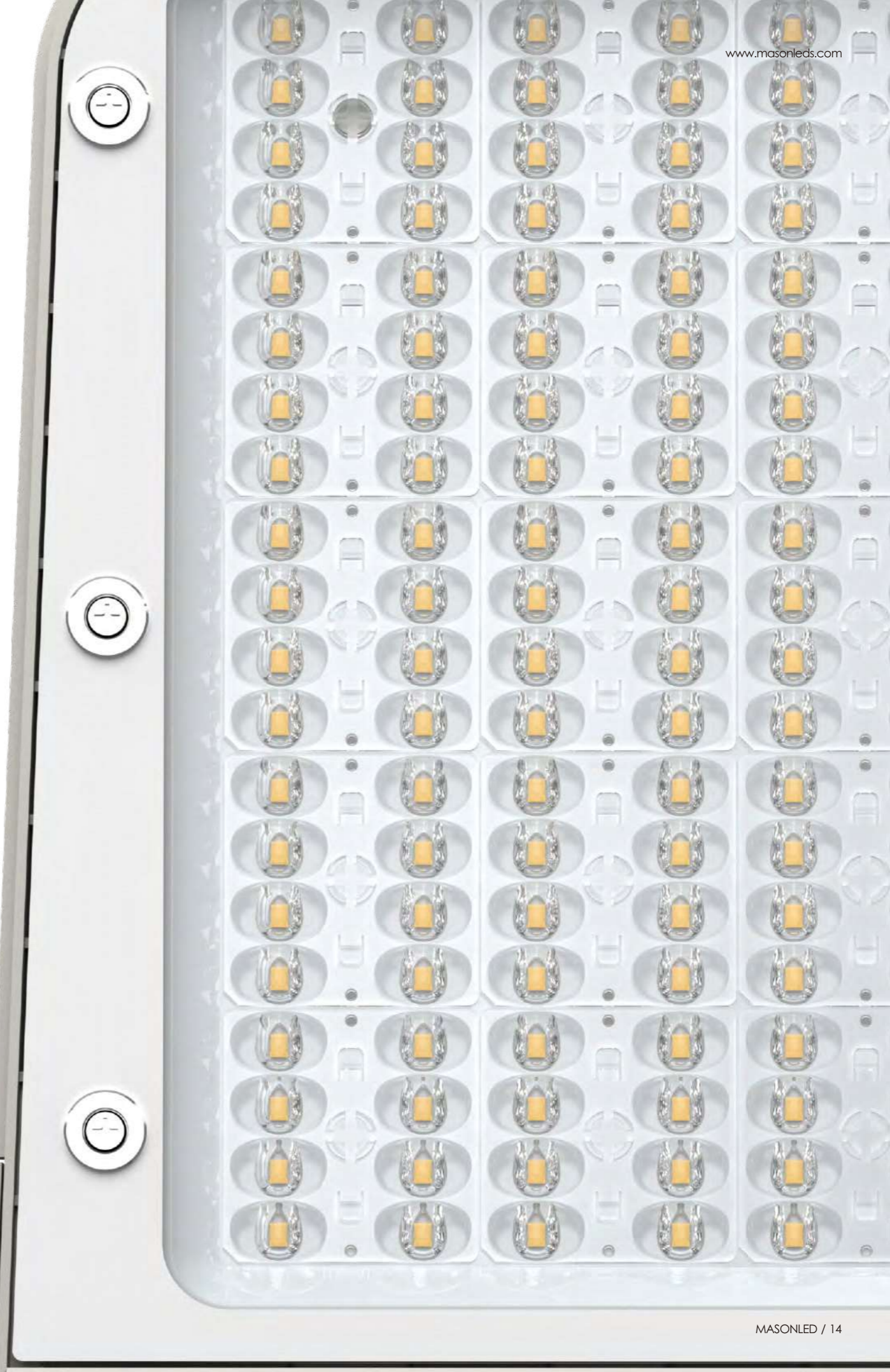
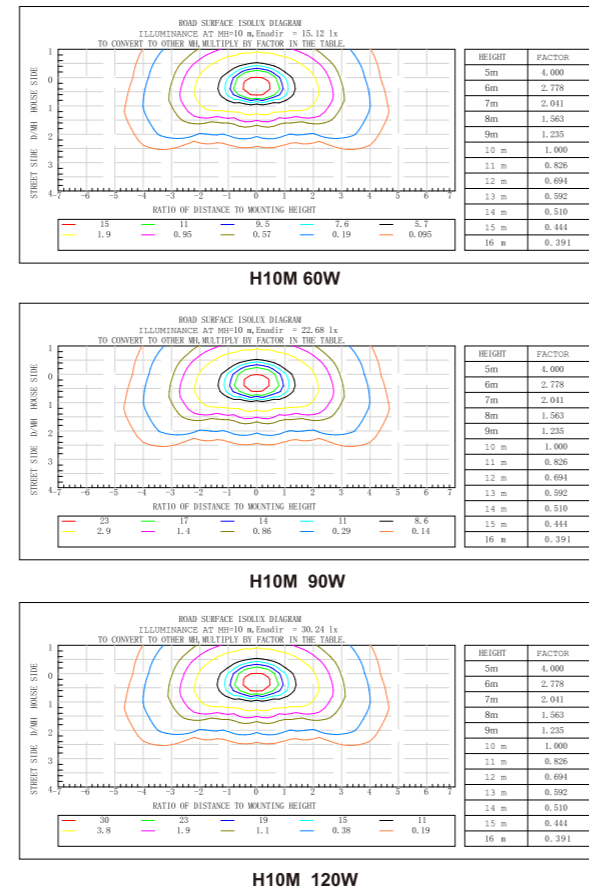

PRODUCT SIZE

Dimension Of Linos

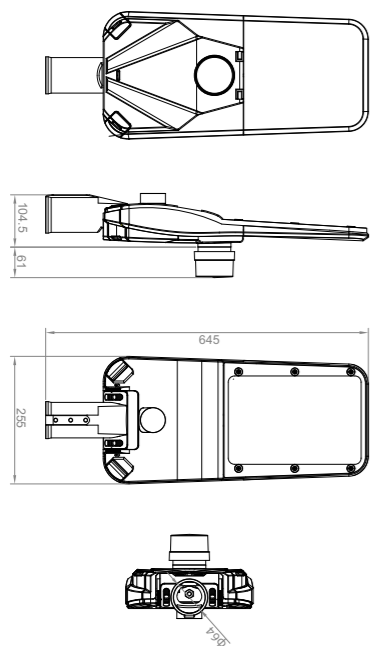

Product	Powerrange	Productsize	N.W.
Linos Micro	20W-50W	535*202*104mm	4.6kg
Linos Mini	60W-100W	645*255*104mm	5.6kg
Linos Midi	110W-150W	695*280*104mm	6.6kg
Linos Large	160W-220W	750*305*104mm	8.6kg
Linos Maxi	230W-300W	810*330*110mm	10.6kg

TECHNICAL SPECIFICATION

LINOS MICRO				
Model No.	MS-ST2001020	MS-ST2002030	MS-ST2003040	MS-ST2004050
Input Voltage	100-277V	100-277V	100-277V	100-277V
PF	>0.95	>0.95	>0.95	>0.95
Power	20W	30W	40W	50W
Light Distribution	Typell~V	Typell~V	Typell~V	Typell~V
Efficiency	180LM/W	180LM/W	180LM/W	180LM/W
CCT	4000K-5000K	4000K-5000K	4000K-5000K	4000K-5000K
CRI	>70	>70	>70	>70
IP Rating	IP66	IP66	IP66	IP66
IK	IK08	IK08	IK08	IK08
Ta	50°	50°	50°	50°
Warranty	5 years	5 years	5 years	5 years
Net Weight	4.6 KG	4.6 KG	4.6 KG	4.6 KG
Packing Size	580*250*150mm	580*250*150mm	580*250*150mm	580*250*150mm

LINOS MINI					
Model No.	MS-ST2005060	MS-ST2006070	MS-ST2007080	MS-ST2008090	MS-ST2009100
Input Voltage	100-277V	100-277V	100-277V	100-277V	100-277V
PF	>0.95	>0.95	>0.95	>0.95	>0.95
Power	60W	70W	80W	90W	100W
Light Distribution	Typell~V	Typell~V	Typell~V	Typell~V	Typell~V
Efficiency	180LM/W	180LM/W	180LM/W	180LM/W	180LM/W
CCT	4000K-5000K	4000K-5000K	4000K-5000K	4000K-5000K	4000K-5000K
CRI	>70	>70	>70	>70	>70
IP Rating	IP66	IP66	IP66	IP66	IP66
IK	IK08	IK08	IK08	IK08	IK08
Ta	50°	50°	50°	50°	50°
Warranty	5 years	5 years	5 years	5 years	5 years
Net Weight	5.6 KG	5.6 KG	5.6 KG	5.6 KG	5.6 KG
Packing Size	695*300*150mm	695*300*150mm	695*300*150mm	695*300*150mm	695*300*150mm

LINOS MIMI					
Model No.	MS-ST2010110	MS-ST2011120	MS-ST2012130	MS-ST2013140	MS-ST2014150
Input Voltage	100-277V	100-277V	100-277V	100-277V	100-277V
PF	>0.95	>0.95	>0.95	>0.95	>0.95
Power	110W	120W	130W	140W	150W
Light Distribution	Typell~V	Typell~V	Typell~V	Typell~V	Typell~V
Efficiency	180LM/W	180LM/W	180LM/W	180LM/W	180LM/W
CCT	4000K-5000K	4000K-5000K	4000K-5000K	4000K-5000K	4000K-5000K
CRI	>70	>70	>70	>70	>70
IP Rating	IP66	IP66	IP66	IP66	IP66
IK	IK08	IK08	IK08	IK08	IK08
Ta	50°	50°	50°	50°	50°
Warranty	5 years	5 years	5 years	5 years	5 years
Net Weight	6.6 KG	6.6 KG	6.6 KG	6.6 KG	6.6 KG
Packing Size	740*320*150mm	740*320*150mm	740*320*150mm	740*320*150mm	740*320*150mm

TECHNICAL SPECIFICATION

LINOS LARGE					
Model No.	MS-ST2015160	MS-ST2016170	MS-ST2017180	MS-ST2018190	MS-ST2019200
Input Voltage	100-277V	100-277V	100-277V	100-277V	100-277V
PF	>0.95	>0.95	>0.95	>0.95	>0.95
Power	160W	170W	180W	190W	200W
Light Distribution	Typell~V	Typell~V	Typell~V	Typell~V	Typell~V
Efficiency	180LM/W	180LM/W	180LM/W	180LM/W	180LM/W
CCT	4000K-5000K	4000K-5000K	4000K-5000K	4000K-5000K	4000K-5000K
CRI	>70	>70	>70	>70	>70
IP Rating	IP66	IP66	IP66	IP66	IP66
IK	IK08	IK08	IK08	IK08	IK08
Ta	50°	50°	50°	50°	50°
Warranty	5 years	5 years	5 years	5 years	5 years
Net Weight	8.6 KG	8.6 KG	8.6 KG	8.6 KG	8.6 KG
Packing Size	790*350*150mm	790*350*150mm	790*350*150mm	790*350*150mm	790*350*150mm

LINOS MAXI					
Model No.	MS-ST2020210	MS-ST2021220	MS-ST2022230	MS-ST2023240	MS-ST2024250
Input Voltage	100-277V	100-277V	100-277V	100-277V	100-277V
PF	>0.95	>0.95	>0.95	>0.95	>0.95
Power	210W	220W	230W	240W	250W
Light Distribution	Typell~V	Typell~V	Typell~V	Typell~V	Typell~V
Efficiency	180LM/W	180LM/W	180LM/W	180LM/W	180LM/W
CCT	4000K-5000K	4000K-5000K	4000K-5000K	4000K-5000K	4000K-5000K
CRI	>70	>70	>70	>70	>70
IP Rating	IP66	IP66	IP66	IP66	IP66
IK	IK08	IK08	IK08	IK08	IK08
Ta	50°	50°	50°	50°	50°
Warranty	5 years	5 years	5 years	5 years	5 years
Net Weight	8.6 KG	8.6 KG	10.6 KG	10.6 KG	10.6 KG
Packing Size	790*350*150mm	790*350*150mm	860*380*150mm	860*380*150mm	860*380*150mm

Model No.	MS-ST2025260	MS-ST2026270	MS-ST2027280	MS-ST2028290	MS-ST2029300
Input Voltage	100-277V	100-277V	100-277V	100-277V	100-277V
PF	>0.95	>0.95	>0.95	>0.95	>0.95
Power	260W	270W	280W	290W	300W
Light Distribution	Typell~V	Typell~V	Typell~V	Typell~V	Typell~V
Efficiency	180LM/W	180LM/W	180LM/W	180LM/W	180LM/W
CCT	4000K-5000K	4000K-5000K	4000K-5000K	4000K-5000K	4000K-5000K
CRI	>70	>70	>70	>70	>70
IP Rating	IP66	IP66	IP66	IP66	IP66
IK	IK08	IK08	IK08	IK08	IK08
Ta	50°	50°	50°	50°	50°
Warranty	5 years	5 years	5 years	5 years	5 years
Net Weight	10.6 KG	10.6 KG	10.6 KG	10.6 KG	10.6 KG
Packing Size	860*380*150mm	860*380*150mm	860*380*150mm	860*380*150mm	860*380*150mm

PACKING INFORMATION

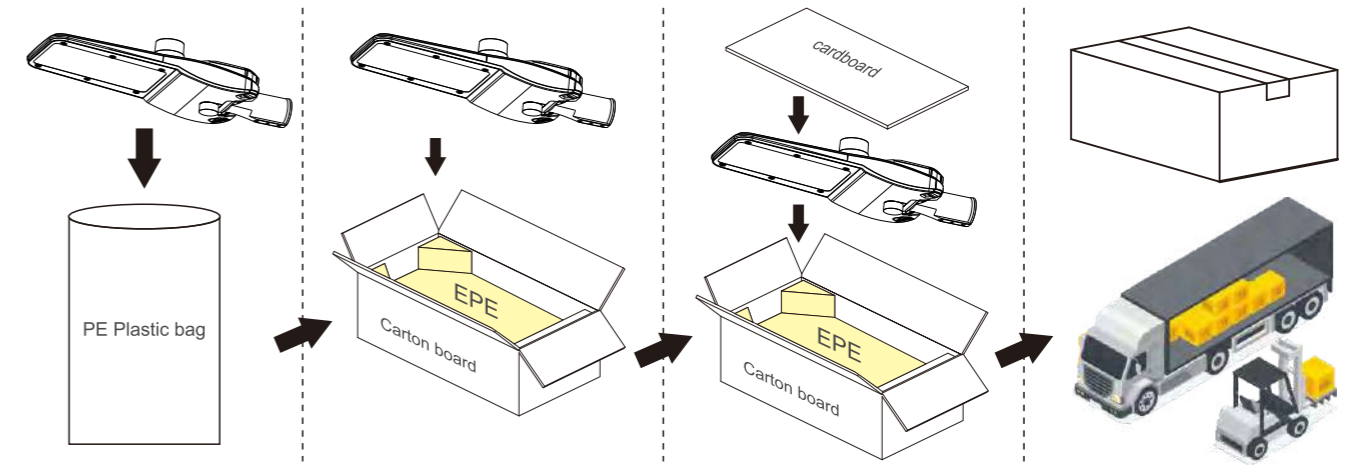

Product	Luminaire power	Carton size (outer box)(mm)	Qty per carton	Packing volume (outer box)
Linus Micro	20W-50W	580*250*150mm	1	0.021
Linus Mini	60W-100W	695*300*150mm	1	0.031
Linus Midi	110W-150W	740*320*150mm	1	0.035
Linus Large	160W-220W	790*350*150mm	1	0.041
Linus Maxi	230W-300W	860*380*150mm	1	0.049

APPLICATION

